

# NELSON™ HEAT TRACING SYSTEMS

## LT-HSS SPLICE KIT

## INSTALLATION INSTRUCTIONS

### DESCRIPTION

The LT-HSS Splice Kit is for use with braided versions of Nelson Heat Tracing Systems' type HLT heater cables in ordinary and hazardous areas.

### KIT CONTENTS

- 5 Uninsulated Splice Connectors
- 10 Insulated Splice Connectors
- 5 Shrink Tubes, 13mm (0.5") diameter, 152mm (6") length

### STRIPPING PROCEDURES

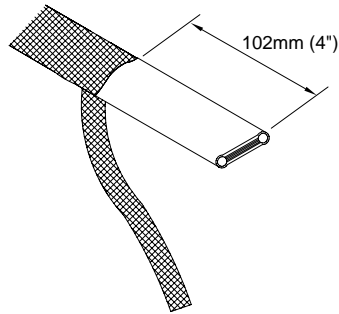

- 1 Unravel approximately 102mm (4") of braid to form a ground strap.

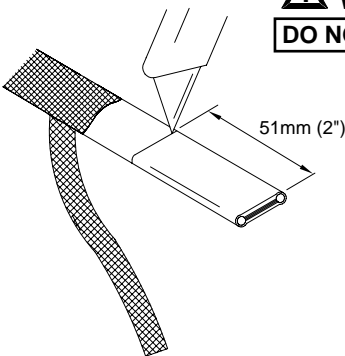

- 2 Lightly cut around heater outer jacket 51mm (2") from the end. Lightly cut the outer jacket up the center between the first cut mark & the cable end. Bend cable to break outer jacket.

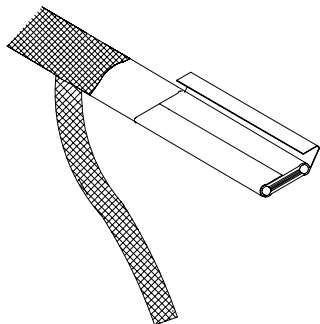

- 3 Remove jacket from the heater cable.

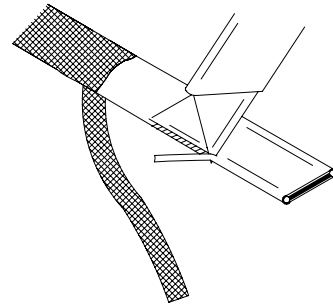

- 4 Shave core material from the outside of each bus wire.

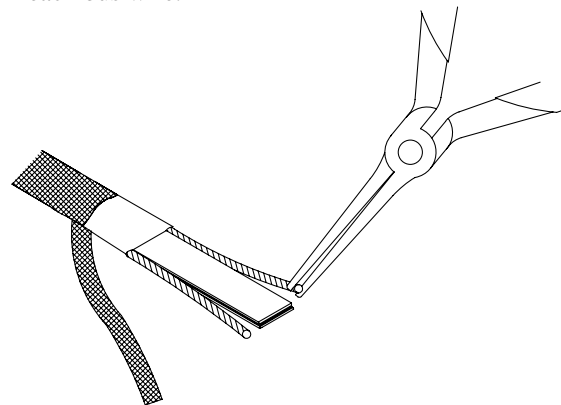

- 5 Starting at the end, pull each bus wire away from the core material and remove exposed core material.

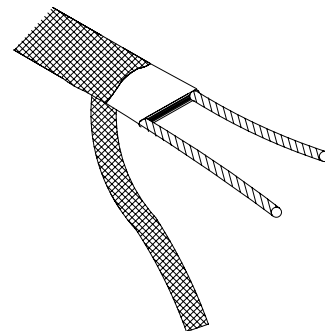

- 7 Repeat steps 1-5 for both heater cables.  
8 Proceed to "Shrink Tube Procedures", sheet 2.

**⚠ WARNING:**  
**DO NOT CUT BUS WIRES**

### SHRINK TUBE PROCEDURES

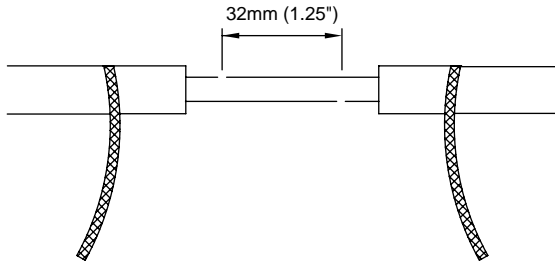

- 1 Position both heater cables with the ground braid on the same side. Remove 32mm (1.25") of bus wire from each heater cable to offset for insulated splice connectors.

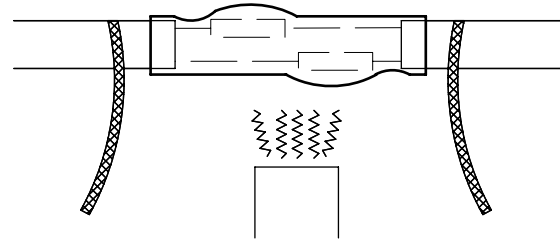

- 3 Center the shrink tube over the connectors leaving the braid straps exposed. Shrink with heat gun until completely shrunk. A uniform bead of glue should appear around the ends of the shrink tube.

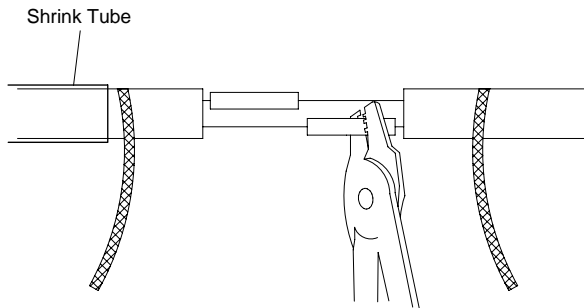

- 2 Slide a shrink tube over one of the heater cables. Crimp an insulated splice connector to each bus wire connecting the two heater cables together.

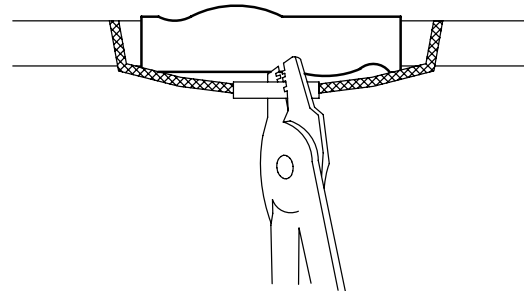

- 4 If necessary, cut excess length from braid straps. Crimp the braid straps together into an uninsulated splice connector. Secure the connector at the indented area with one and a half wraps of fiberglass tape (*not included in kit*).

Nelson Heat Tracing Systems products are supplied with a limited warranty. Complete Terms and Conditions may be found on Nelson's website at [www.nelsonheaters.com](http://www.nelsonheaters.com).

#### DESCRIPTION

The LT-HST Tee Splice Kit is for use with braided versions of Nelson Heat Tracing Systems' type HLT heater cables in ordinary and hazardous areas.

#### KIT CONTENTS

- 5 Wire Ties
- 2 Tubes of Silicone
- 5 Uninsulated Splice Connectors
- 10 Insulated Splice Connectors
- 5 Shrink Tubes, 13mm (0.5") diameter, 152mm (6") length

#### STRIPPING PROCEDURES

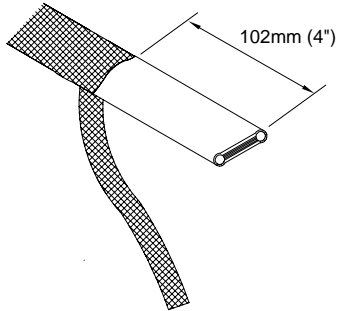

- 1 Unravel approximately 102mm (4") of braid to form a ground strap.

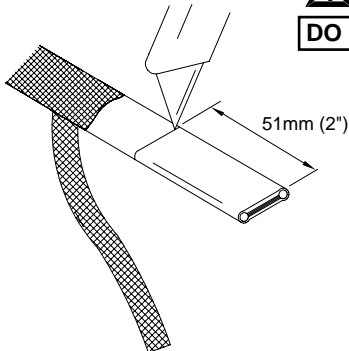

- 2 Lightly cut around heater outer jacket 51mm (2") from the end. Lightly cut the outer jacket up the center between the first cut mark & the cable end. Bend cable to break outer jacket.

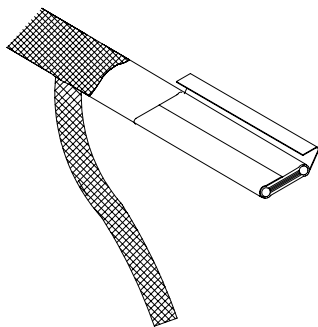

- 3 Remove jacket from the heater cable.

**⚠ WARNING:**  
**DO NOT CUT BUS WIRES**

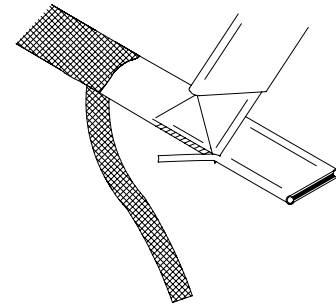

- 4 Shave core material from the outside of each bus wire.

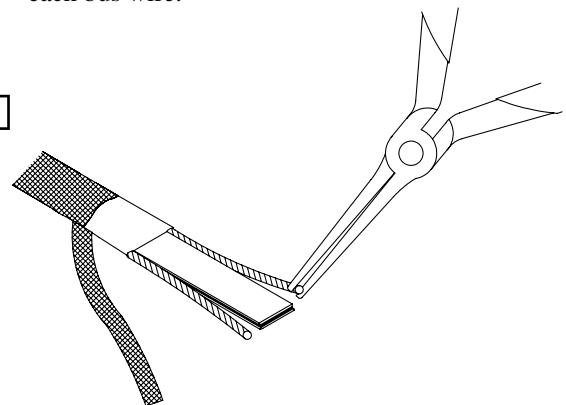

- 5 Starting at the end, pull each bus wire away from the core material and remove exposed core material.

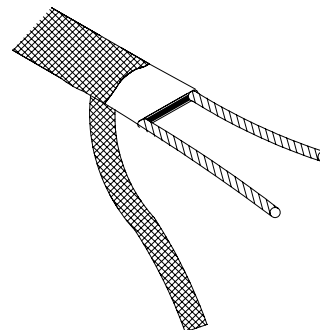

- 7 Repeat steps 1-5 for all heater cables.  
8 Proceed to "Shrink Tube Procedures", sheet 2.

### SHRINK TUBE PROCEDURES

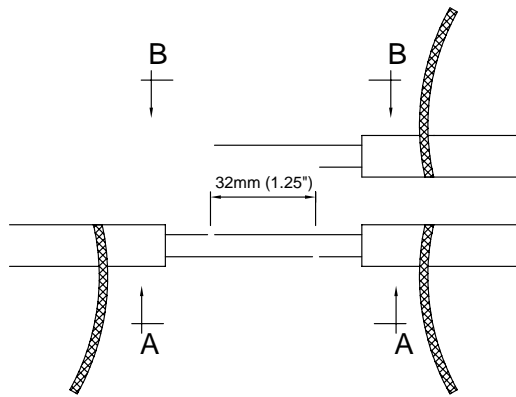

- 1 Position three heater cables with the ground braid on the same side. Remove 32mm (1.25") of bus wire from each heater cable to offset for the insulated splice connectors.

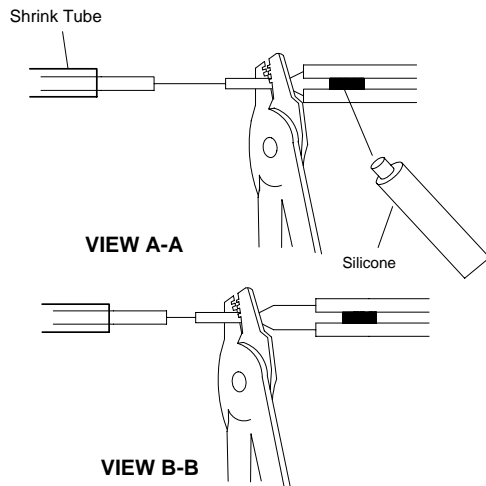

- 2 Slide a shrink tube over the single heater cable side. Twist bus wires together from the two heater cables and crimp into insulated splice connectors, then connect to the single heater cable.
- 3 Inject a generous amount of silicone between the two heater cables forming a moisture barrier.

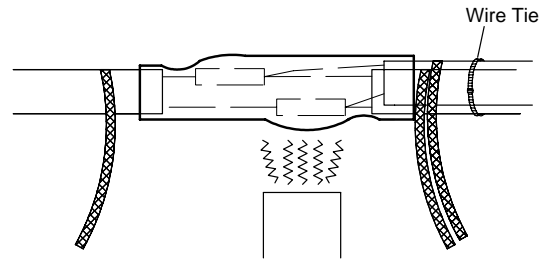

- 4 Center the shrink tube over the connectors leaving the braid straps exposed. Shrink with heat gun until completely shrunk. A uniform bead of glue should appear around the ends of the shrink tube.
- 5 Fasten a wire tie around the two heater cables to hold in place.

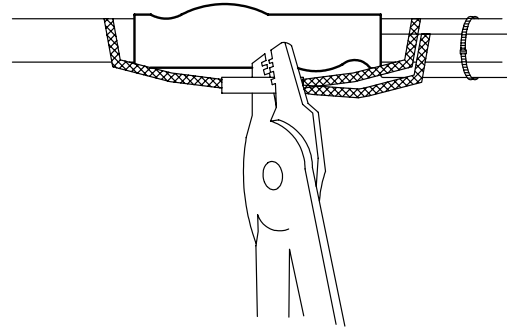

- 6 If necessary, cut excess length from braid straps. Crimp the braid straps together into an uninsulated splice connector. Secure connector at the indented area with one and a half wraps of fiberglass tape (*not included in kit*).

Nelson Heat Tracing Systems products are supplied with a limited warranty. Complete Terms and Conditions may be found on Nelson's website at [www.nelsonheaters.com](http://www.nelsonheaters.com).

### LT-MP POWER END TERMINATION KIT

#### DESCRIPTION

The LT-MP Power End Termination Kit is for use with all versions of Nelson Heat Tracing Systems' LT, CLT, HLT and NC heater cables. Compatible for use with any vendor's heater cables smaller than 11mm (0.44") diameter.

#### KIT CONTENTS

- 5 Power Terminations
- 1 Tube of Silicone

#### OVERJACKET PRODUCTS

For Braided Products proceed to step 4 below.

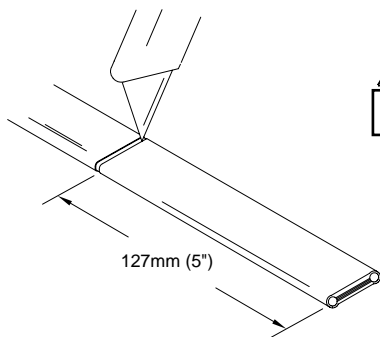

**⚠ WARNING:**  
**DO NOT CUT BRAID**

- 1 Lightly cut around heater overjacket 127mm (5") from the end. Bend cable to break the overjacket.
- 2 Lightly cut overjacket up the center between first cut mark and the cable end. Bend cable to break the overjacket.

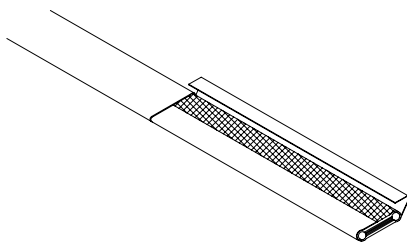

- 3 Remove overjacket from heater cable.

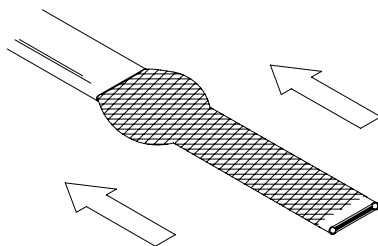

- 4 Move braid back toward the overjacket, creating a bulge.

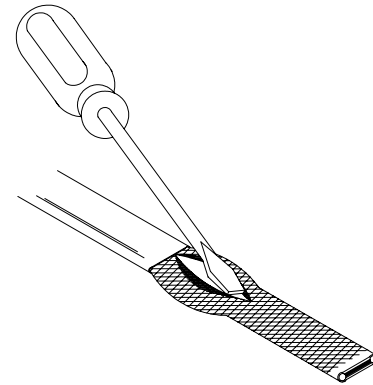

- 5 At the bulge, separate the braid to make an opening.

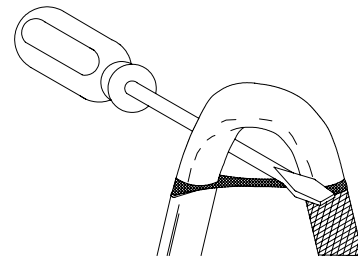

- 6 While bending the heater cable, work it through the braid opening.

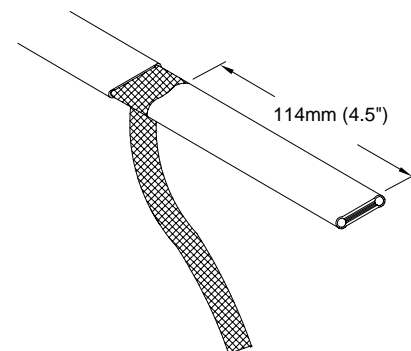

- 7 Pull the braid tight.
- 8 Proceed to "LT, CLT & HLT Products", sheet 2.

#### FOR ALL NELSON LT, CLT & HLT PRODUCTS

(See sheet 3 for an alternate method of HLT products.)

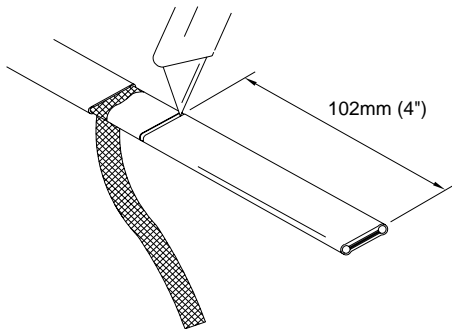

- 1 Lightly cut around cable outer jacket 102mm (4") from the end. Bend cable to break outer jacket.
- 2 Lightly cut the outer jacket up the center between the first cut mark & the cable end. Bend cable to break outer jacket.

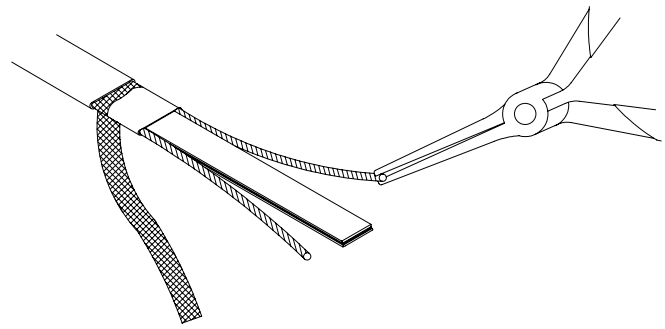

- 5 Starting at the end, pull each bus wire away from the core material.
- 6 Remove exposed core material.

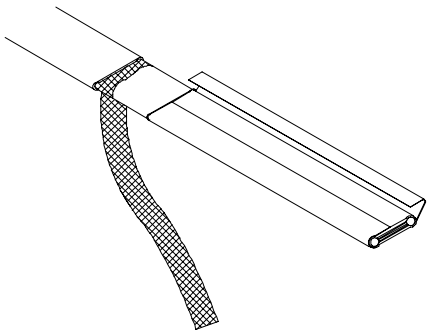

- 3 Remove the jacket from the heater cable.

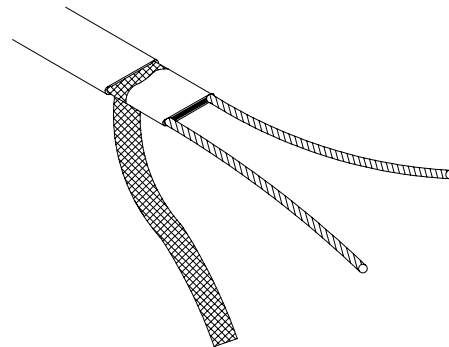

- 7 Cut 6mm (0.25") off the end of each bus wire.
- 8 Proceed to "Power Termination" on sheet 7.

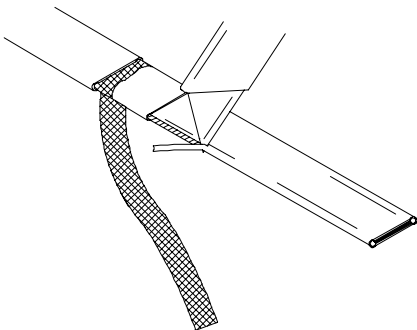

- 4 Shave the core material from the outside of each bus wire.

**⚠ WARNING:**  
DO NOT CUT BUS WIRES

### HLT PRODUCTS ALTERNATE STRIPPING METHOD

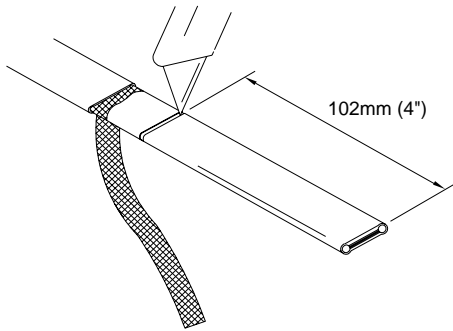

- 1 Lightly cut around cable outer jacket 102mm (4") from the end. Bend cable to break outer jacket.
- 2 Lightly cut the outer jacket up the center between the first cut mark & the cable end. Bend cable to break outer jacket.

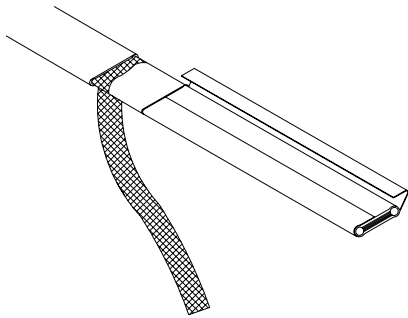

- 3 Remove the jacket from the heater cable.

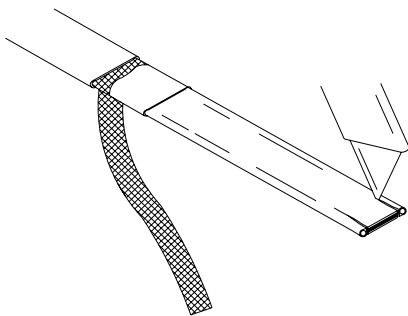

- 4 Make a cut inside each bus wire.

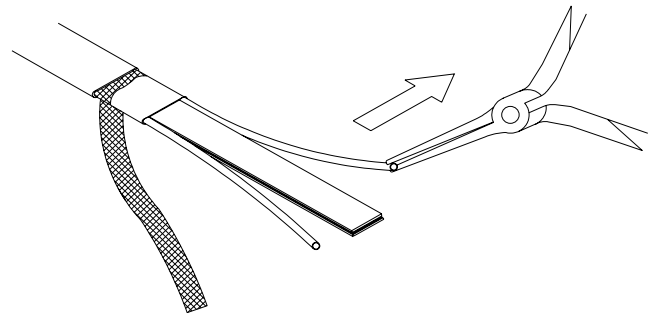

- 5 Starting at the end, in the same plane as the cable, pull each bus wire away from the core material.

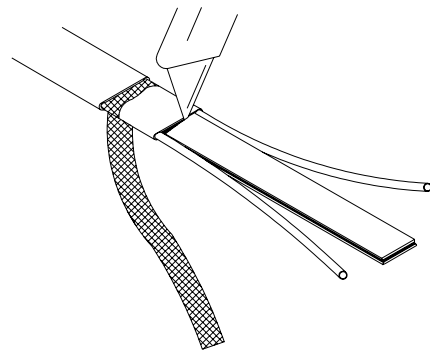

- 6 Remove the exposed core material.

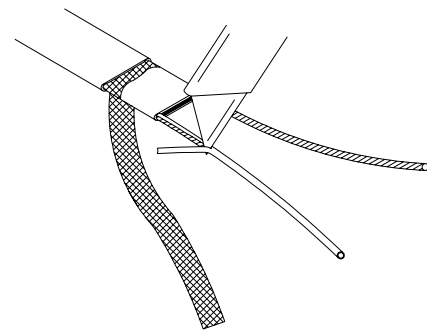

- 7 Remove the remaining core material off the outside of each bus wire.
- 8 Cut 6mm (0.25") off the end of each bus wire.
- 9 Proceed to "Power Termination" on sheet 7.

#### POWER TERMINATION

#### **⚠ WARNING:**

- Bus wires must not touch or cross while inserting into power termination.
- Only power terminations / end seals specifically approved for the vendor's style and type of heater cable must be

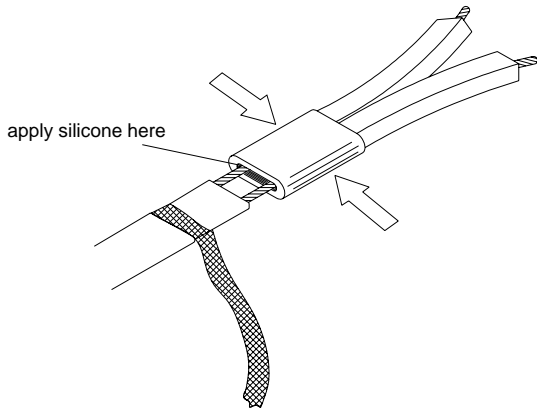

- ❶ Insert bus wires into power termination.
- ❷ Squeeze power termination opening and fill with silicone.

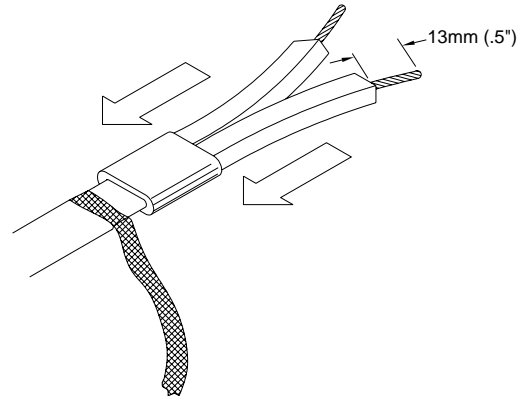

- ❸ Push power termination to overlap jacket.
- ❹ The silicone will set up in about 30 minutes with a complete cure after 24 hours.
- ❺ Proceed to "*Power Termination*" on sheet 8.

#### **⚠ WARNING:**

- Do not megger or hi-pot until silicone is completely cured.
- Braid must be kept away from bus wires or shorting will occur.

Nelson Heat Tracing Systems products are supplied with a limited warranty. Complete Terms and Conditions may be found on Nelson's website at [www.nelsonheaters.com](http://www.nelsonheaters.com).



# NELSON™ HEAT TRACING SYSTEMS

## LT-P SMALL PIPE ADAPTER KIT FOR USE WITH PLT OR LT CONNECTION KITS

## INSTALLATION INSTRUCTIONS

### DESCRIPTION

The LT-P Small Pipe Adapter Kit is for use with PLT or LT connection kits to mount to small diameter pipes or tubes. Covers a size range up to 19mm (.75") tubing and 13mm (.50") pipe.

### KIT CONTENTS

- 1 Small Adapter Plate
- 2 Pipe Clamps

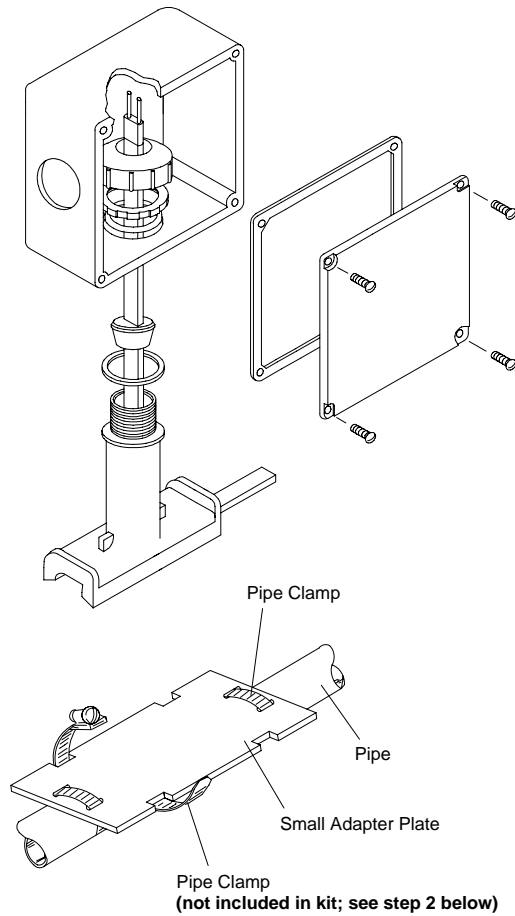

PLT

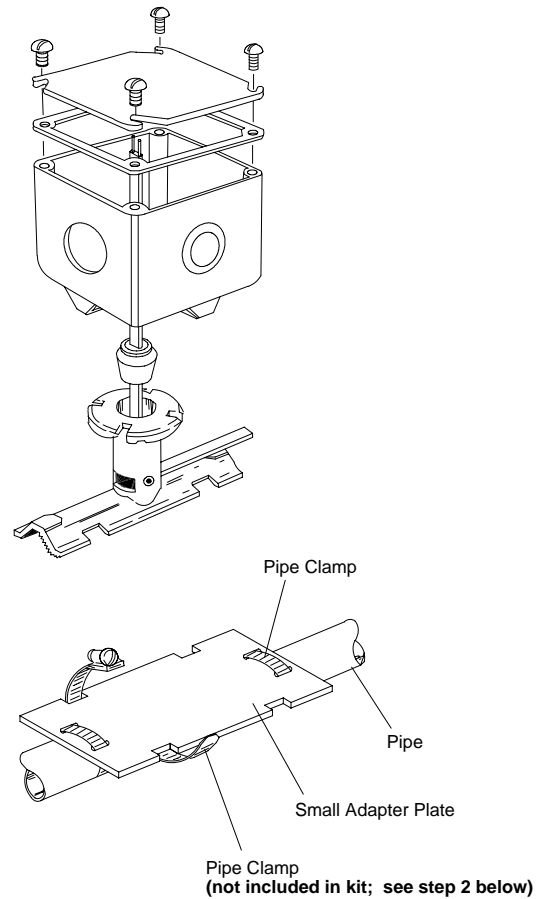

LT

1. Install the small adapter plate with pipe clamps included in kit.
2. Mount stand-off with pipe clamps supplied in the PLT or LT connection kits.

Nelson Heat Tracing Systems products are supplied with a limited warranty. Complete Terms and Conditions may be found on Nelson's website at [www.nelsonheaters.com](http://www.nelsonheaters.com).

# NELSON™ HEAT TRACING SYSTEMS

## LT-SS SPLICE KIT

## INSTALLATION INSTRUCTIONS

### DESCRIPTION

The LT-SS Splice Kit is for use with all versions of Nelson Heat Tracing Systems' LT & CLT heater cables except for J option. Minimum installation temperature  $-30^{\circ}\text{C}$  ( $-22^{\circ}\text{F}$ ).

### KIT CONTENTS

- 5 Uninsulated Splice Connectors
- 10 Insulated Splice Connectors
- 5 Shrink Tubes, 13mm (0.5") diameter, 152mm (6") length
- 5 Shrink Tubes, 16mm (0.63) diameter, 229mm (9") length

### OVERJACKET STRIPPING PROCEDURES

*For Braided "CB" Products proceed to step below.*

**⚠ WARNING:**  
**DO NOT CUT BRAID**

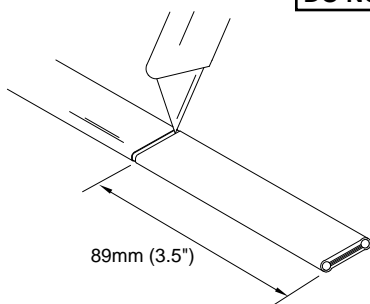

- 1 Lightly cut around heater overjacket 89mm (3.5") from the end. Bend cable to break the overjacket.
- 2 Lightly cut overjacket up the center between first cut mark and the cable end. Bend cable to break

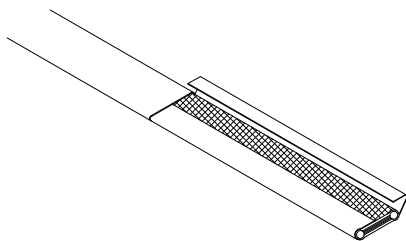

- 3 Remove overjacket from heater cable.

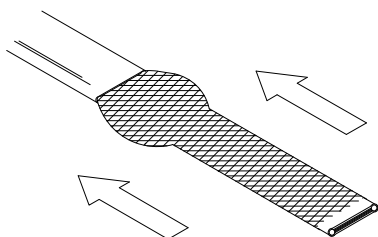

- 4 Move braid back toward the overhacket, creating a bulge.

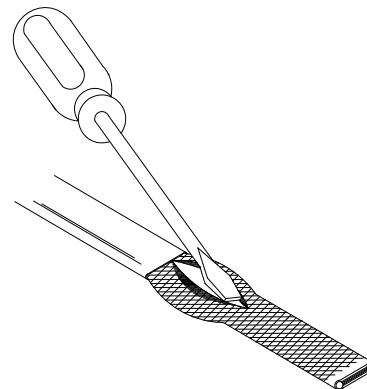

- 5 At the bulge, separate the braid to make an opening.

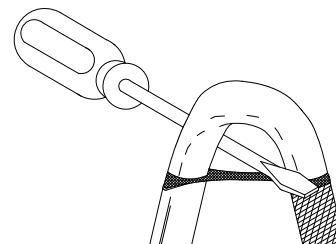

- 6 While bending the heater cable, work it through the braid opening.

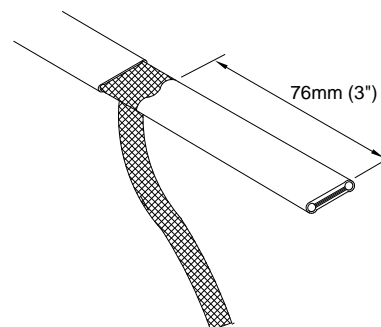

- 7 Pull braid tight.
- 8 Repeat steps 1 - 7 for both heater cables.
- 9 Proceed to "Outer Jacket Stripping Procedures", sheet 2.

### OUTER JACKET STRIPPING PROCEDURES

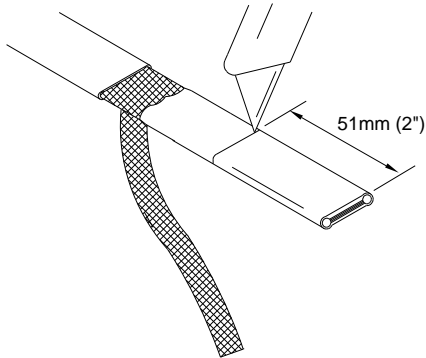

- 1 Lightly cut around heater outer jacket 51mm (2") from the end. Bend cable to break outer jacket.
- 2 Lightly cut the outer jacket up the center between the first cut mark & the cable end. Bend cable to break outer jacket.

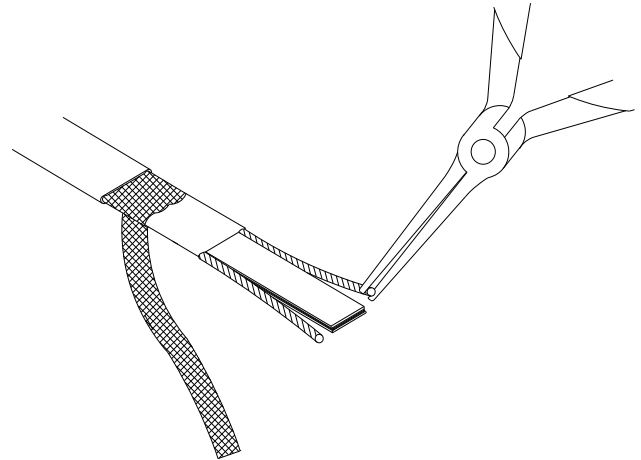

- 5 Starting at the end, pull each bus wire away from the core material.
- 6 Remove exposed core material.

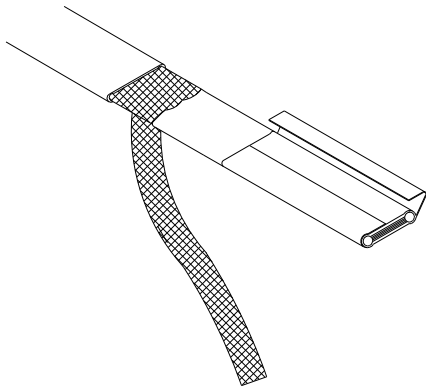

- 3 Remove jacket from the heater cable.

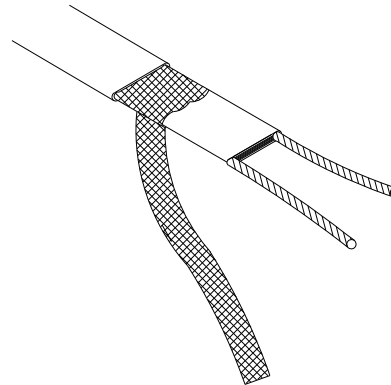

- 7 Repeat steps 1 - 6 for both heater cables.
- 8 Proceed to "Shrink Tube Procedures", sheet 3

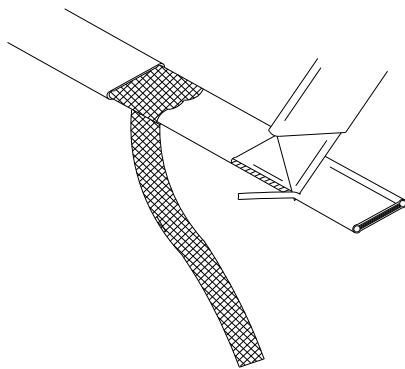

- 4 Shave core material from the outside of each bus wire.

**⚠ WARNING:**  
**DO NOT CUT BUS WIRES**

### SHRINK TUBE PROCEDURES

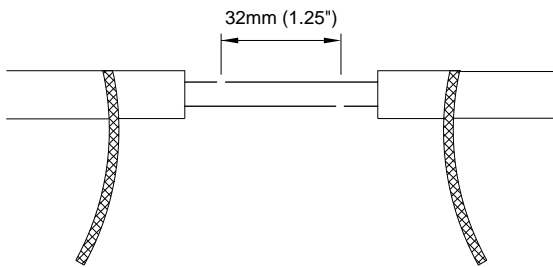

- 1 Position both heater cables with the ground braid on the same side. Remove 32mm (1.25") of bus wire from each heater cable to offset for insulated splice connectors.

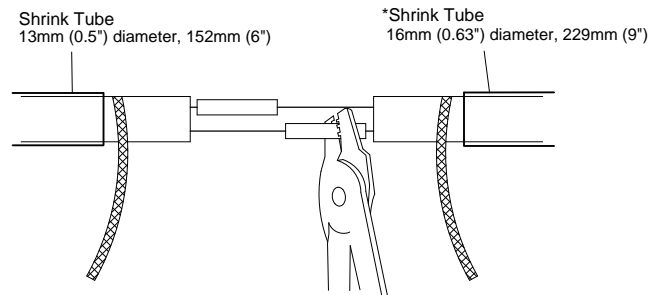

- 2 Slide one 13mm (0.5") diameter, 152mm (6") length shrink tube over one of the heater cables. Crimp an insulated splice connector to each bus wire connecting the two heater cables together.

**\*For Overjacket "JT" Products only:**

Slide one 16mm (0.63") diameter, 229mm (9") length shrink tube over the other heater cable. See diagram above.

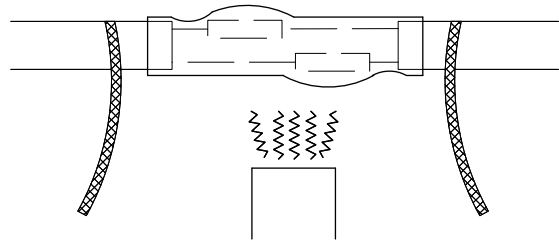

- 3 Center the 13mm (0.5") diameter, 152mm (6") length shrink tube over the connectors leaving the braid straps exposed. Shrink with heat gun until completely shrunk. A uniform bead of glue should appear around the ends of the shrink tube.

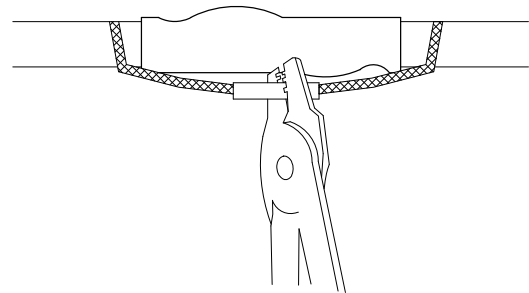

- 4 If necessary, cut excess length from braid straps. Crimp the braid straps together into an uninsulated splice connector. Secure the connector at the indented area with one and a half wraps of fiberglass tape (not included in kit).

**\*For Overjacket "JT" Products only:**

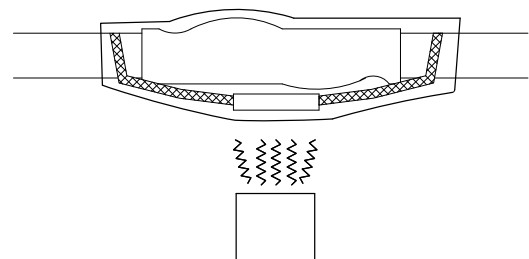

- 5 Center the 16mm (0.63") diameter, 229mm (9") length shrink tube over the splice and braid connection. Shrink with heat gun until completely shrunk. A uniform bead of glue should appear around the ends of the shrink tube.

Nelson Heat Tracing Systems products are supplied with a limited warranty. Complete Terms and Conditions may be found on Nelson's website at [www.nelsonheaters.com](http://www.nelsonheaters.com).

### DESCRIPTION

The LT-ST Tee Splice Kit is for use with all versions of Nelson Heat Tracing Systems' LT & CLT heater cables except for J option. Minimum installation temperature – 30°C (-22°F).

### KIT CONTENTS

- 5 Wire Ties
- 5 Mastic Strips
- 5 Uninsulated Splice Connectors
- 10 Insulated Splice Connectors
- 5 Shrink Tubes, 13mm (0.5") diameter, 152mm (6") length
- 5 Shrink Tubes, 16mm (0.63") diameter, 229mm (9") length

### OVERJACKET STRIPPING PROCEDURES

*For Braided "CB" Products proceed to step 4 below.*

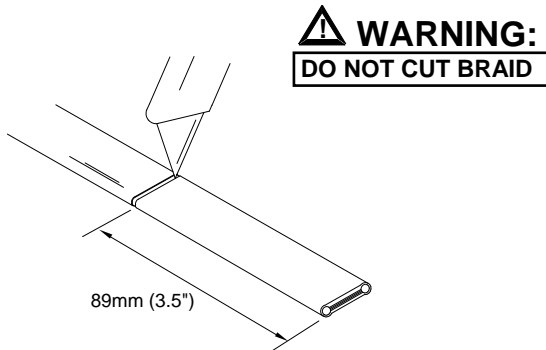

- 1 Lightly cut around heater overjacket 89mm (3.5") from the end. Bend cable to break the overjacket.
- 2 Lightly cut overjacket up the center between first cut mark and the cable end. Bend cable to break

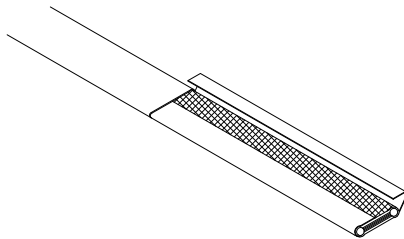

- 3 Remove overjacket from heater cable.

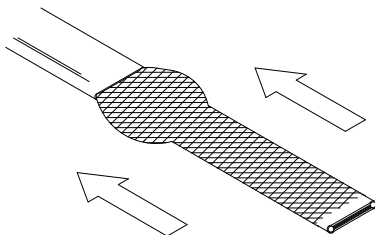

- 4 Move braid back toward the overhacket, creating a bulge.

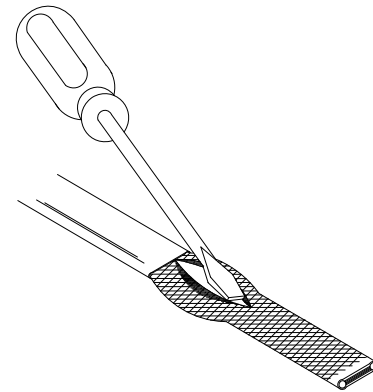

- 5 At the bulge, separate the braid to make an opening.

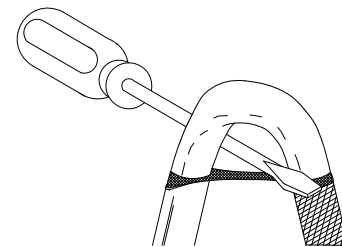

- 6 While bending the heater cable, work it through the braid opening.

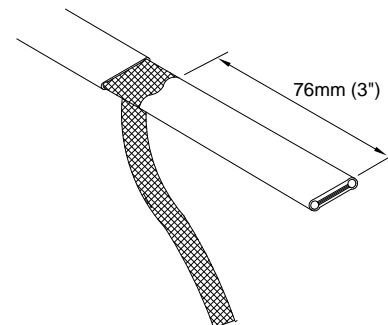

- 7 Pull braid tight.
- 8 Repeat steps 1 - 7 for both heater cables.
- 9 Proceed to "Outer Jacket Stripping Procedures", sheet 2.

### OUTER JACKET STRIPPING PROCEDURES

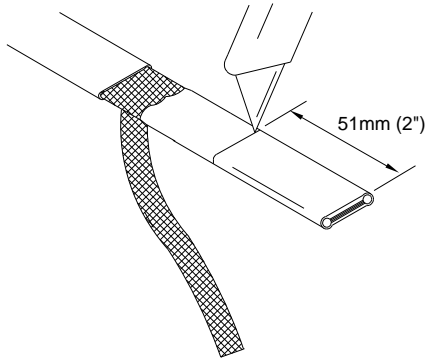

- 1 Lightly cut around heater outer jacket 51mm (2") from the end. Bend cable to break outer jacket.
- 2 Lightly cut the outer jacket up the center between the first cut mark & the cable end. Bend cable to break outer jacket.

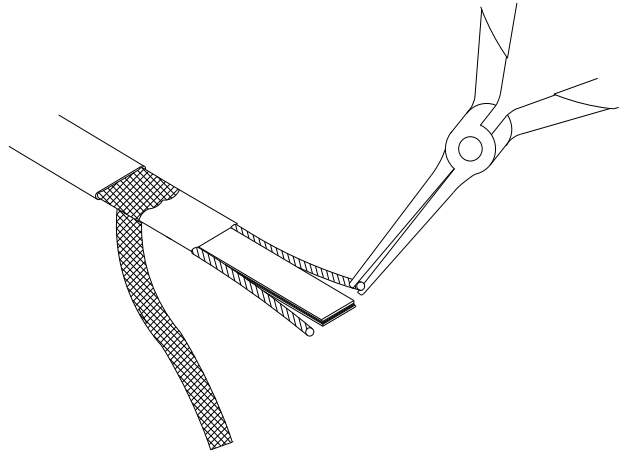

- 5 Starting at the end, pull each bus wire away from the core material.
- 6 Remove exposed core material.

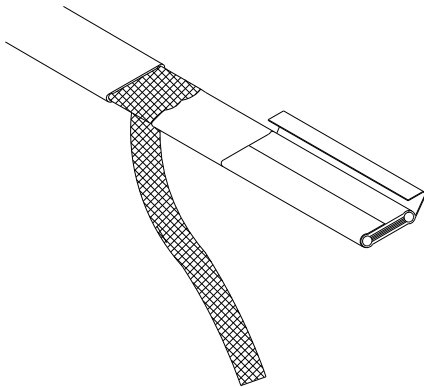

- 3 Remove jacket from the heater cable.

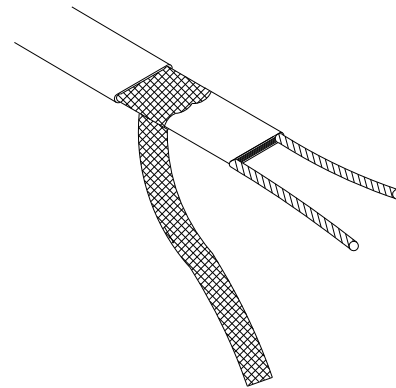

- 7 Repeat steps 1 - 6 for both heater cables.
- 8 Proceed to "Shrink Tube Procedures", sheet 3

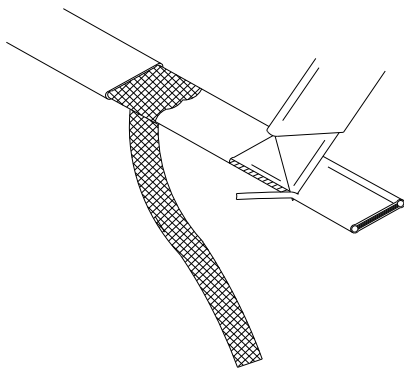

- 4 Shave core material from the outside of each bus wire.

**⚠ WARNING:**  
**DO NOT CUT BUS WIRES**

### SHRINK TUBE PROCEDURES

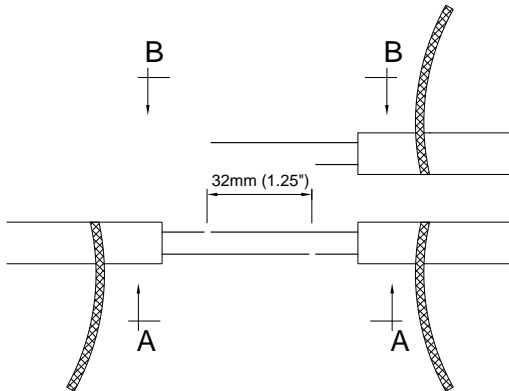

- 1 Position three heater cables with the ground braid on the same side. Remove 32mm (1.25") of bus wire from each heater cable to offset for the insulated splice connectors.

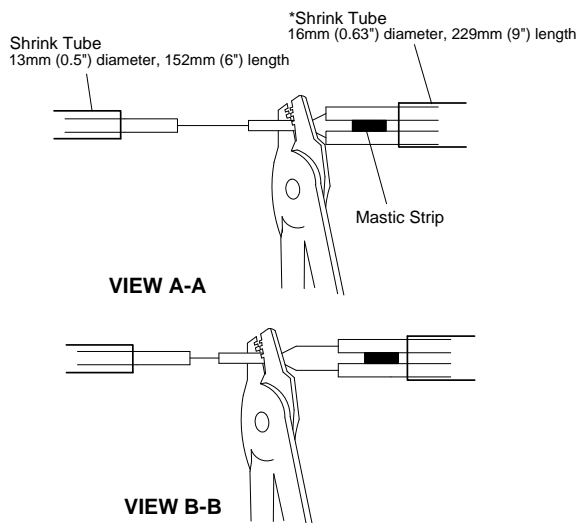

- 2 Slide one 13mm (0.5") diameter, 152mm (6") length shrink tube over the single heater cable side. Twist bus wires together from the two heater cables and crimp into insulated splice connectors, then connect to the single heater cable. Place a mastic strip between the two heater cables forming a moisture barrier.

**\*For Overjacket "JT" Products only:**

Slide one 16mm (0.63") diameter, 229mm (9") length shrink tube over the two heater cables side.  
*See diagram above.*

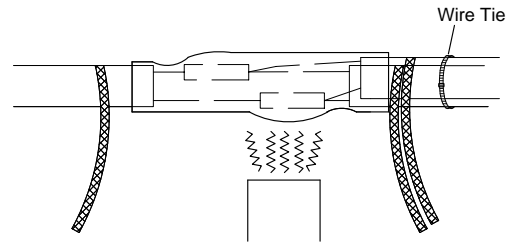

- 3 Center the 13mm (0.5") diameter, 152mm (6") length shrink tube over the connectors leaving the braid straps exposed. Make sure the shrink tube covers the mastic strip. Shrink with heat gun until completely shrunk. A uniform bead of glue should appear around the ends of the shrink tube. Fasten a wire tie around the two heater cables to hold in place.

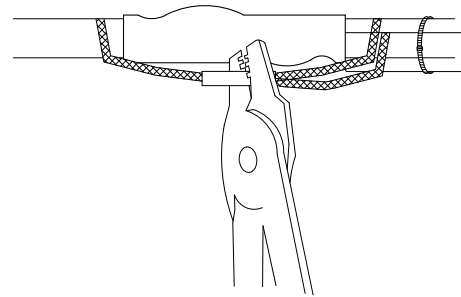

- 4 If necessary, cut excess length from braid straps. Crimp the braid straps together into an uninsulated splice connector. Secure connector at the indented area with one and a half wraps of fiberglass tape (not included in kit).

**\*For Overjacket "JT" Products only:**

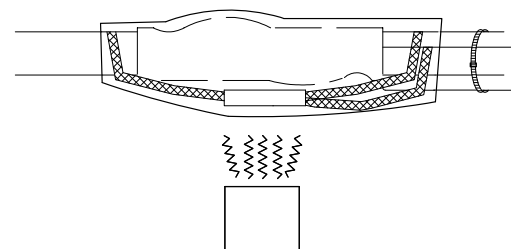

- 5 Center the 16mm (0.63") diameter, 229mm (9") length shrink tube over the splice and braid connection. Shrink with heat gun until completely shrunk. A uniform bead of glue should appear around the ends of the shrink tube.

Nelson Heat Tracing Systems products are supplied with a limited warranty. Complete Terms and Conditions may be found on Nelson's website at [www.nelsonheaters.com](http://www.nelsonheaters.com).

# NELSON™ HEAT TRACING SYSTEMS

## LT-T TANK ADAPTER KIT

FOR USE WITH PLT, ALT OR LT CONNECTION KITS

INSTALLATION  
INSTRUCTIONS

### DESCRIPTION

The LT-T Tank Adapter Kit is for use with the PLT, ALT or LT connection kits for mounting on a vessel.

### KIT CONTENTS

- 1 Tank Adapter Bracket
- 2 Tubes of Silicone

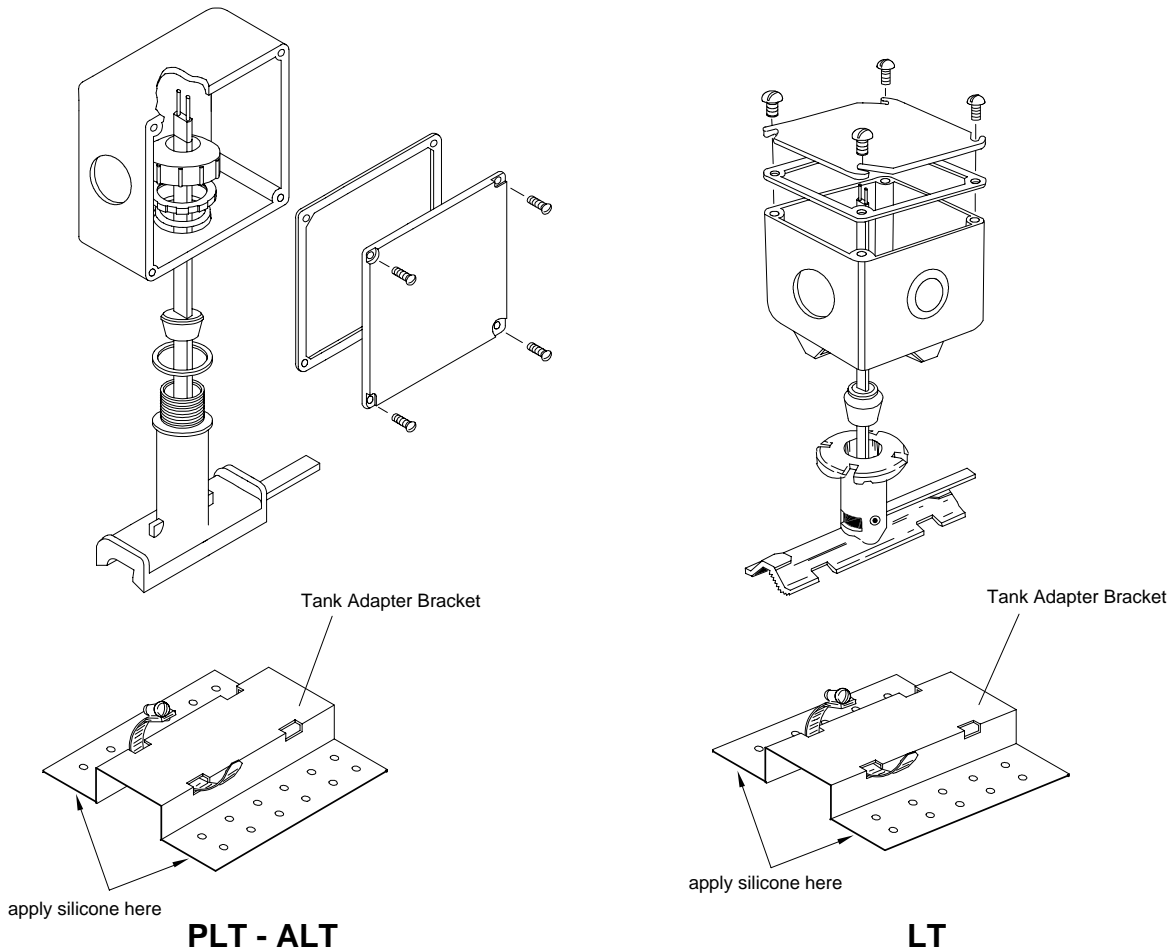

- ❶ To insure proper mounting of the tank adapter bracket, select a convenient location.
- ❷ Allow at least 457mm (18") of loose heater cable for each tank adapter bracket used.
- ❸ Thoroughly clean mounting surface, approximately 6" sq., so that it is free of all foreign material.
- ❹ Apply (1) tube of silicone to each foot of the tank adapter bracket and firmly press into place.

### **⚠ WARNING:**

**Allow 24 hours for silicone to dry before mounting stand-off to the tank adapter bracket.**

Nelson Heat Tracing Systems products are supplied with a limited warranty. Complete Terms and Conditions may be found on Nelson's website at [www.nelsonheaters.com](http://www.nelsonheaters.com).



# NELSON™ HEAT TRACING SYSTEMS

## LT-ME END SEAL KIT

## INSTALLATION INSTRUCTIONS

### DESCRIPTION

The LT-ME End Seal Kit is for use with all versions of Nelson Heat Tracing Systems' LT, CLT, HLT and NC heater cables. Compatible for use with any vendor's heater cables smaller than 11mm (0.44") diameter. Minimum installation temperature -40°C (-40°F).

### KIT CONTENTS

- 5 End Seals
- 1 Tube of Silicone

### WARNING:

Only end seals specifically approved for the vendor's style and type of heater cable must be used.

### END SEAL INSTALLATION

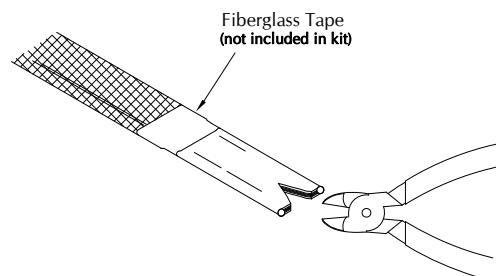

#### 1 For Braided Products:

Cut braid back 25mm (1") & tape in place with fiberglass tape (not included in kit).

#### For Overjacket Products:

Remove 13mm (0.5") of overjacket exposing the braid, then remove the 13mm (0.5") of exposed braid.

- 2 Make a 10mm (0.4") cut at the end of the heater cable.

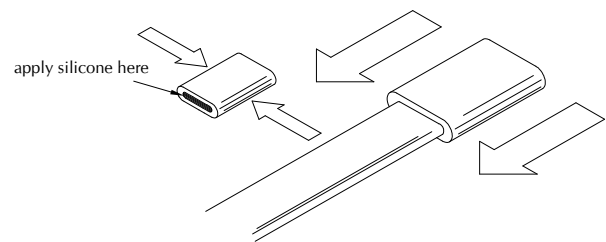

- 3 Squeeze the end seal and fill with silicone.  
4 Push end seal over the heater cable.

#### For Overjacket Products:

The end seal should overlap the overjacket.

- 5 The silicone will set up in about 30 minutes with a complete cure after 24 hours.

### WARNING:

- Do not megger or hi-pot until silicone is completely cured.
- Braid must be kept away from bus wires or shorting will occur.

Nelson Heat Tracing Systems products are supplied with a limited warranty. Complete Terms and Conditions may be found on Nelson's website at [www.nelsonheaters.com](http://www.nelsonheaters.com).